

FUKUDA

DC Power Supply Systems

Rectifier / Battery Charger

FUKUDA TPU series, a constant voltage, thyristor controlled Rectifier / Battery Charger with built in with 'Slow Start' and Current Limiting function provide a short circuiting fail safe system guarantee a reliable DC Power Supply to your Switch Gear tripping system.

Design with modular concept and well identified wiring and components for easy installation and maintenance.

To meet the specific needs of each application

FUKUDA TPU Series can be equipped with wide range of options which include alarms, breakers, filters, etc.

FUKUDA TPU S1 Series – Single charging system

FUKUDA TPU S2 Series – Dual, 'parallel and redundant' charging system

Benefits : -

- *Ideal for charging nickel cadmium or lead acid battery.*
- *Modular design with full range of options.*
- *Fully regulated output voltage.*
- *Constant voltage charging.*
- *Reverse battery protection.*
- *Short circuit failsafe design.*
- *Automatic current limit.*
- *Soft start circuit.*

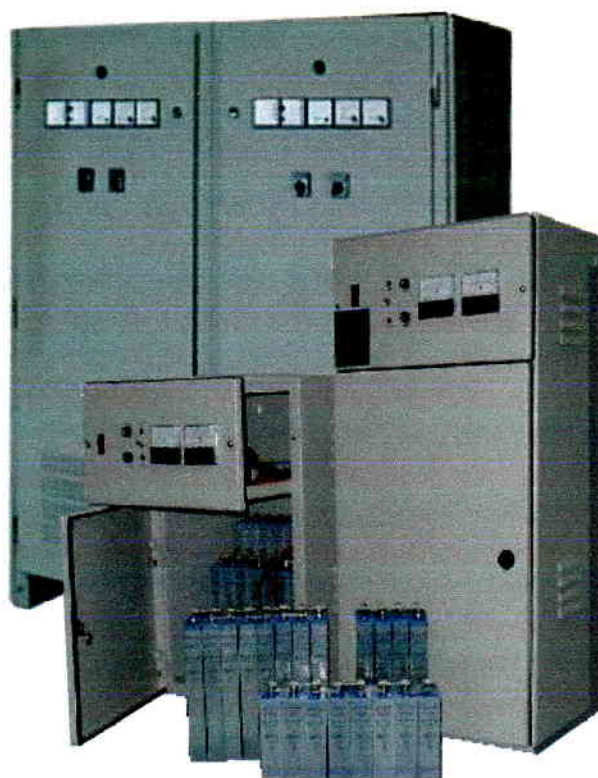

FUKUDA RECTIFIER - the preferred choice

FUKUDA range of rectifier has been developed to meet the most severe industrial standard. Primarily in the oil and gas, chemical and petrochemical industries, power generation and distribution, telecommunication and other domains where highest availability of stable DC power source are required.

EXTENSIVE RANGE

FUKUDA has a wide range to select. Single phase rectifier employs two pulse fully controlled thyristor bridge, whereas the three phase unit has a six pulse fully controlled bridge. A twelve pulse bridge configuration for reduction in mains harmonics current is also available. Voltage outputs ranging from 6Vdc to 250Vdc and current outputs ranging from 3Adc to 1600Adc is available. The cabinets are either floor or wall mounted. Special cabinet size, index of protection and colour can also be adapted for the system.

MINIMUM MAINTENANCE

The rectifier requires only occasional maintenance and checking. No special tools are required. In addition to its ease of operation, **FUKUDA** rectifier has ensure optimal service ability. Well layout design ensures all components to be front accessible. In the unlikely event of fault, the alarm display indicates exactly where the problems lies, allowing error-tracing and repair to be carried out swiftly. Replacement of printed circuit board is made easy with pull out connectors.

EASE OF OPERATION

The rectifier is designed to be user friendly. Upon completion of the commissioning of the unit, it automatically maintains the battery in its full state of charge. Even after any power interruption, the rectifier shall restore the battery to its fully capacity without any human intervention.

VERSATILITY

FUKUDA rectifiers are adaptable to a wide range of applications. The FD-1 and FD-3 series are eminently suited for equipment in which delicate electronics are used. This is to suit the sophisticated and time-critical environments of various applications.

HIGH QUALITY

This power electronic equipment is designed and built in accordance with the IEC/EN standards. The carefully selected components adhering to guidelines of an international body, result in a very reliable equipment. Stringent testing accordance to IEC 146 further assures that finished products are delivered with the highest quality.

APPLICATION STANDARDS

FUKUDA power electronics equipment is designed and built according to the applicable sections of IEC standards or other standards / specifications as approved by clients.

Technical Features - Standard Product

INPUT VOLTAGE

380V or 415V 3 Ph \pm 10%

INPUT FREQUENCY

50 or 60 Hz \pm 6%

MAINS FUSE

Recommended (see technical data)

OUTPUT VOLTAGE

Nominal : 12V, 24V, 48V, 110V
or 220V DC

Floating : 80% to approximately
135% of V nominal

High rate : 80% to approximately
135% of V nominal

CHARGE CHARACTERISTICS

Constant current/constant voltage (I/V
as per IEC 478-1) during float charge.

OUTPUT STATIC STABILITY (STANDARD)

\pm 1% with DC load and simultaneous
variations in AC input of \pm 10% and
frequency variation of \pm 6%

OUTPUT CURRENT

5A to 1500A maximum continuous,
adjustable 20 – 100% of Inom

CURRENT REGULATION

\pm 2% current limit.

TEMPERATURE COEFFICIENT

0.03% per °C (of output V)

LONG TERM STABILITY

0.15% per 1000 hrs (of output V)

RIPPLE VOLTAGE

Battery connected:

Maximum 1 % RMS of nominal DC
voltage provided battery capacity is
5 times the charger nominal current
rating.

Battery not connected:

Maximum 5% RMS of nominal DC
voltage.

PROTECTION

Current limitation at 110% of rated
current short circuit protected. Slow
start device AC input surge suppressors
DC output fuse

CONTROL

Rectifier on/off Manual timed
high-rate/Auto/Float

INDICATORS

Rectifier on (Green)
Float (Green)
High Rate (Red)

DEGREE OF RADIO FREQUENCY INTERFERENCE

G. According to VDE 0875 (optional N.)

APPLICABLE STANDARDS

IEC/VDE

HIGH VOLTAGE INSULATION

2KV AC for 1 minute between input/
output and electrical earth

INSULATION RESISTANCE

10 Mohm with 500VDC between
input/output and electrical earth

AMBIENT TEMPERATURE OPERATIONAL

-10 to +40°C

+40 to +55°C derate current
rating by 1.25% per °C

STORAGE

-25 to 70°C

ATTITUDE

To 1000m

1000m to 4000m derate 6.7%/1000m

VENTILATION

Natural convection, sufficient clearance
required above and in front of the
cubicle at least 500mm. Chargers/
rectifiers with normal output current of
300A and above have natural
convection with forced air.

NOISE LEVEL

Maximum 65 dBA according D/N 45632

INSTRUMENTS

Chargers output voltmeter and
Ammeter 72 x 72mm, 1.5% accuracy
90 defect for MG 36 & 47 cabinet.
96 x 96mm 1.5% accuracy 90°
deflection for MG 62 & 62D cabinet

AUTO CHARGE CONTROL

Auto charge control for automatic
switching to high rate after battery
discharge and back to float charge
after the battery is fully charged.
(Standard 8 hours).

Technical Features - Optional

STANDARD ALARM PACKAGE

CHARGER FAIL

Used for sensing failures in the charger by monitoring the voltage and current functions.

LOW DC VOLTAGE

Used for sensing low voltage.

Adjustment: 70 – 150% V nominal

Hysteresis: 2%

Usual settings:

- battery low voltage: 1.1V/c NiCd,
1.8 Lead Acid

HIGH DC VOLTAGE

Used for sensing high voltage.

Adjustment: 70 – 150% V nominal

Hysteresis: 2%

Usual settings:

- battery high voltage: 1.7V/c NiCd,
2.5V/c Lead Acid

EARTH FAULT

Discriminate sensing of positive and negative earth faults in ungrounded systems.

Fault current adjustment set @ 10mA

Hysteresis: 2%

AC FAIL

Used for sensing low mains voltage.

INDICATORS

All alarms are indicated by red LED's on the frontdoor.

GROUP REMOTE ALARM

A group remote alarm relay is included as a standard feature. The relay has a potential free change over contact and is de-energized upon alarm.

240V AC, 5A, 480VA

100V DC, 5A, 120W

LED TEST/RESET

All alarms are latched after being activated. Two pushbuttons facilities for LED test and rest of alarms.

LOW ELECTROLYTE LEVEL ALARM

An alarm module in conjunction with a probe installed on a pilot cell in the battery will signal low electrolyte level. This option is only available for Nickel Cadmium batteries containers.

OTHER ALARM FEATURES ON REQUEST

SELECTIVE REMOTE ALARM

A selective remote alarm system is available as option and can be installed for each alarm or for selected alarms only. For contact rating see group remote alarm.

AUDIBLE ALARM

For local annunciation of a selected alarm function or as group alarm.

OVERTEMPERATURE

The alarm indicates excessive high temperature and initiates charger shutdown by inhibiting the control to the rectifier bridge.

DC FUSE TRIP ALARM

Indication of blown on DC load output fuse.

LOW VOLTAGE DISCONNECT ALARM

Low voltage disconnect, to disconnect the load from the battery when the voltage level decreases below a preset level. The option includes an output contactor. Manual reset after battery voltage reaches a preset level.

HIGH VOLTAGE SHUTDOWN ALARM

High voltage shutdown to shutdown the charger when this output voltage exceeds a preset level. The option includes an input circuit breaker with shunt trip.

Technical Features - Optional

OTHER FEATURES ON REQUEST

METERING AND TRANSDUCER

Additional analogue or digital metering is available. The angle of deflecting can be of 240 degrees. Transducers for remote monitoring can also be included.

- Battery voltmeter and ammeter
- Input voltmeter and ammeter
- Load voltmeter and ammeter
- Input power and power factor meter
- 4 to 20mA transducer for remote metering

NON-STANDARD CABINET

Upon request, the cabinet can be painted with a non-standard colour if available. Colour codes are Munsell or RAL. The degree of protection (IP rating as according to IEC529 e.g IP21, 32, 43 etc) can be increased to suit different environment.

AUTO TRANSFER SWITCH

An automatic transfer switch can be installed at the incoming line when there are two sources of incoming supply. The switch automatically transfers the main incoming supply to the alternate supply when the main supply fails. A selection switch can be included for the selection of either supply as the main supply.

PARALLEL-LOAD SHARING

Additional blocking diode is recommended at each charger output. Load sharing card to load share several chargers can be connected in parallel.

LOAD SHEDDING CIRCUIT

Contactors together with timers are used to shed the respective load at different time elapse on battery discharging.

REVERSE BATTERY POLARITY PROTECTION

The internal components of the equipment are protected with an added protection circuit installed in the equipment. This option is to avoid the damage caused to the equipment when the battery bank and rectifier meet at opposite polarity.

INTERIOR CABINET LIGHTING

An interior cabinet light is provided with a door interlocking switch. The interior light is only operated when the door is open and switches off automatically when door closes.

BATTERY TEST

An internal load is built in the charger to perform a discharge on the battery to reconfirm the functionality of the battery. The battery test is carried out with the rectifier providing to the load.

CIRCUIT BREAKERS

The circuit breakers can be installed at different points along the system to enhanced each application. Shunt tripping, motorised breaker, high breaking capacity breaker, padlocking, mechanical interlocking, electrical interlocking and other features of the breakers can be included.

- Miniature Circuit Breaker (upto 100A)
- Mould Case Circuit Breakers (upto 1600A)
- Air Circuit Breaker (for higher current)

BATTERY BOX

Battery breakers or fuses can be located inside a high grade plastic / polycarbonate box or a metal enclosure.

SLOW RECHARGING OF CAPACITORS

This option is recommended when the equipment is designed with a battery switch or breaker. The filtering capacitors are always present. A step input voltage bank can generate a very high current.

BATTERY ROOM FAN CONTROL

A voltage free contact signal can be provided to the charger unit to inhabit the Hi-Rate activity upon failure of the battery room fan.

Technical Features - Optional

TELECOM FILTER

Psophometric ripple voltages are measured within a specific bandwidth described under the CCITT norms which state that for telecom purposes, the requirements must match the "C" curve. The ripple voltage requirement is 0.1% of the nominal output and 2mV psophometric value.

INPUT EMI FILTER

An input EMI filter is installed if requirement specify a normalised limited for conducted Electrical Magnetic Interference (EN50082-2)

BATTERY CURRENT LIMIT

This option is used to prevent excessive charging current to the connected battery. Whenever the battery current reaches a preset value, the rectifier will be current limited independent of the load current.

BATTERY TEMP. COMPENSATION

This option is used whenever a battery needs charge compensation with respect to the ambient temperature. The charge voltage decreases automatically when the ambient temperature of the battery increases.

OTHERS

Please consult our sales personnel for other options.

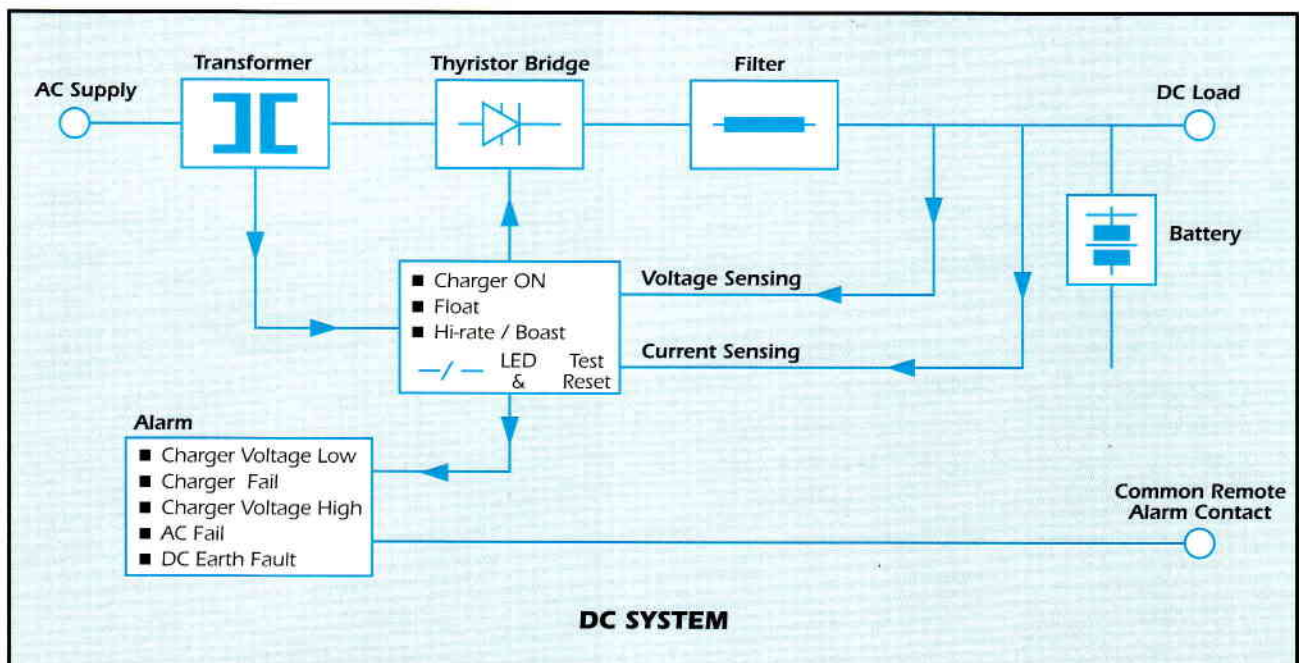

Other System Configuration On Request

DROPPING DIODE DEVICES

Battery voltage controlled output voltage regulation with dropping diodes. Limiting of the load voltage to $\pm 10\%$ of the V nominal instrument for DC output voltage is provided with a change over switch for measuring the load or battery voltage. With separate unregulated output for non critical load.

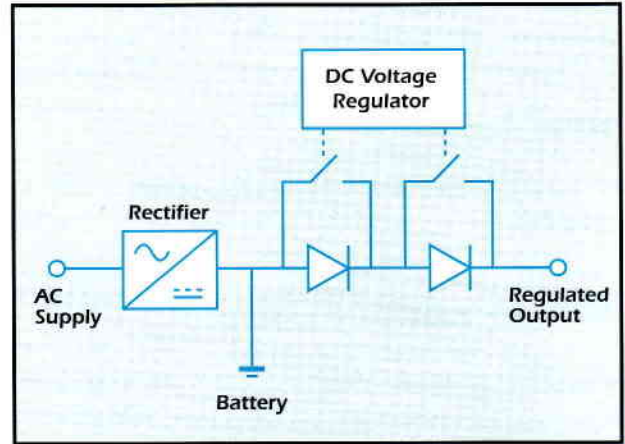

LOAD CURRENT SHARING (DUAL DC SYSTEM)

To adjust the output current of the charger/rectifier when connected in parallel with others for redundancy. Each charger/rectifier gives the same proportion or its full load capacity.

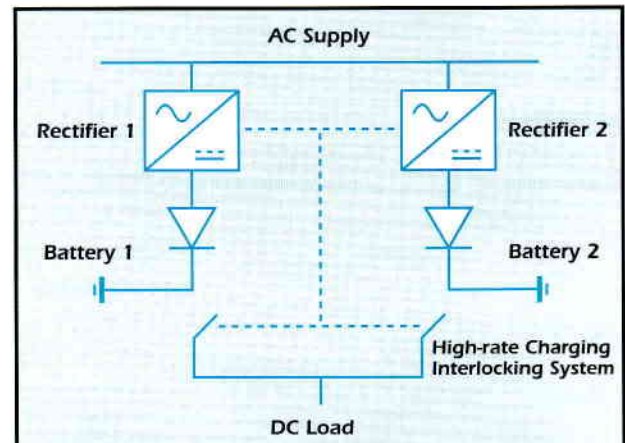

END CELL SWITCHING (HOT STANDBY SYSTEM)

Output voltage regulation with divided battery. An uninterruptable change over switch connect the additional cells in series with main battery after load voltage has reached its lower level and disconnect as soon as the upper level is reached. A voltmeter change over switch "battery/load" is included in this option.

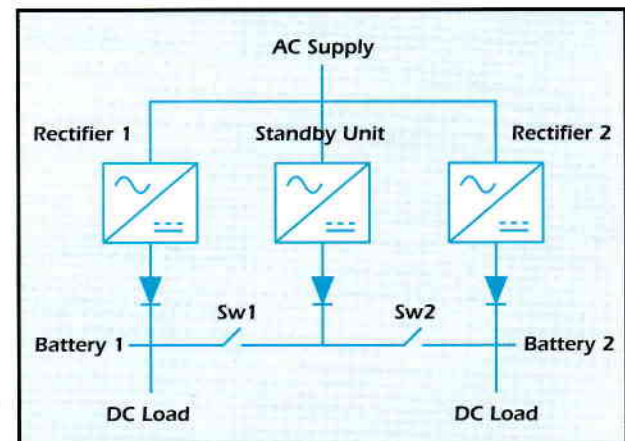

TPU Single Phase & Three Phase Rectifier / Battery Charger Technical Data

Rectifier Input (AC)

Voltage	: 110 / 220 / 230 / 240Vac	: 220/ 380 / 400 / 415Vac
Phase	: 1 Phase	: 3 Phase
Voltage Variation	: +/- 10%	: +/- 10%
Frequency	: 50Hz +/-6% or 60Hz	: 50Hz +/-6% or 60Hz

Rectifier Output (DC)

System Voltage	: 24, 30, 48, 110 & 220 Vdc
Float Voltage	: 80 - 135% (Adjustable)
High Rate Voltage (Boost)	: 90 - 145% (Adjustable)
Commissioning Voltage	: Up to 155% (Adjustable)
Float Voltage Staic Regulation	: +/- 1% (at +/- 10% Input Voltage Variation)
Dynamic Voltage Regulation (10% - 100% and 100-10% Load Step)	: Maximum Voltage Dip 5% and Recovery Time is max. 250ms
Ripple Voltage (without Battery Connected)	: RMS \leq 5%
Ripple Voltage (with Battery Connected)	: RMS \leq 2% (when battery Ah is min. 4 times of that charger rating)
Current Output Ratings	: 3 - 1200Ampere
Output Current Limitation	: 50 - 110% Nom (Accuracy: +/- 2%)
Battery Current Limitation	: 10 - 100% Nom (Accuracy: +/-2 %)

General Data

Storage Temperature	: -20 to +70° C
Operation Temperature	: -10 to +40° C (>40 to +55° C derate 1.25% per ° C)
Altitude	: Up to 1000m
Humidity	: \leq 95% RM (non-condensing)
Audible Noise	: \leq 65dBA at 1m
Stabilized power supplies DC output	: IEC 60478
Electrical Measurement Instrument	: IEC 60051
Power Transformers	: IEC 60076
Performance Test	: IEC 60146
Degree of Protection	: IP 20 ~ IP 54
Cabinet Colour	: RAL 7032 (Light grey)
Cooling	: Natural Convection
Dielectric Insulation Test	: 2kV for 1 minute between Input and Output to Earth
Insulation Resistance Test	: \geq 10 Mohm at 500Vdc Input and Output to Earth
Protection -Rectifier Input	: Soft start function & surge suppressor
Protection -Rectifier Output	: Protected against short circuit
Protection -Battery Output	: Polarity reversal of battery
Protection -Current Limiting	: Adjustable between 5% to 105% of nominal current

Indicator and Optional Accessories

Standard Features	Status	Description
Control Board		
Charger On	Green	Charge on operation mode
Float Charge	Green	Normal operation maintains the battery in fully charged condition
High Rate Charge (Boost)	Orange	High Rate Charge restores the battery to fully capacity, by manual or automatic selection Auto High Rate Charge reverts back to Float Charge after the battery fully charge

Standard Alarm Indicators	Status	Description
Multi-Alarm Board		
Charger Failure	Red	Individual or Common Volt Free Contact
DC Low Voltage	Red	Individual or Common Volt Free Contact
DC High Voltage	Red	Individual or Common Volt Free Contact
DC Earth Fault (positive or negative)	Red	Individual or Common Volt Free Contact
Low Electrolyte Level	Red	Individual or Common Volt Free Contact
Mains Failure	Red	Individual or Common Volt Free Contact

Optional Features	Status	Description
Multi-Alarm Board		
Battery MCB / MCCB Trip of Fuse Blown	Red	Individual or Common Volt Free Contact
Battery Cabinet Temperature High / Low	Red	Individual or Common Volt Free Contact
Battery Voltage High / Low	Red	Individual or Common Volt Free Contact
Charger Cabinet Temperature High / Low	Red	Individual or Common Volt Free Contact
Load Output Voltage High / Low	Red	Individual or Common Volt Free Contact

Optional Features / Accessories
Audible Alarm Buzzer
Battery Low Voltage Disconnect
Transducer 4 to 20mA dc
Digital Meter
Cabinet Lighting
Dropping Diode Devices

Cabinet Dimension & Weight

TPU Single - Phase Battery Charger

Type	Nom. Volt. Vdc	Nom Cur. Adc	Cabinet	Wgt kg
TPU 12-3	12	3	A15	13
TPU 12-6	12	6	A15	15
TPU 12-10	12	10	A15	17
TPU 12-15	12	15	A15	20
TPU 12-20	12	20	A21	25
TPU 12-25	12	25	A21	30
TPU 12-30	12	30	A21	32
TPU 12-35	12	35	A21	35
TPU 12-40	12	40	A21	37
TPU 12-50	12	50	B36	40
TPU 12-60	12	60	B36	42
TPU 12-75	12	75	B36	45
TPU 12-100	12	100	B36	92

TPU 24-3	24	3	A16	17
TPU 24-6	24	6	A19	19
TPU 24-10	24	10	A21	27
TPU 24-15	24	15	A21	32
TPU 24-20	24	20	A21	35
TPU 24-25	24	25	A21	42
TPU 24-30	24	30	A21	43
TPU 24-35	24	35	A23	45
TPU 24-40	24	40	B36	50
TPU 24-50	24	50	B36	95
TPU 24-60	24	60	B36	105
TPU 24-75	24	75	B36	115
TPU 24-100	24	100	B36	130

TPU 30-3	30	3	A16	17
TPU 30-6	30	6	A19	19
TPU 30-10	30	10	A23	27
TPU 30-15	30	15	A23	32
TPU 30-20	30	20	A23	35
TPU 30-25	30	25	B36	42
TPU 30-30	30	30	B36	43
TPU 30-35	30	35	B36	45
TPU 30-40	30	40	B36	50
TPU 30-50	30	50	B36	95
TPU 30-60	30	60	B36	105
TPU 30-75	30	75	B47	115
TPU 30-100	30	100	B47	130

Type	Nom. Volt. Vdc	Nom Cur. Adc	Cabinet	Wgt kg
TPU 48-3	48	3	A22	20
TPU 48-6	48	6	A22	24
TPU 48-10	48	10	A23	24
TPU 48-15	48	15	A23	39
TPU 48-20	48	20	A23	80
TPU 48-25	48	25	A21	83
TPU 48-30	48	30	A21	85
TPU 48-35	48	35	B36	90
TPU 48-40	48	40	B36	100
TPU 48-50	48	50	B36	135
TPU 48-60	48	60	B36	155
TPU 48-75	48	75	B47	200
TPU 48-100	48	100	B47	230

TPU 110-3	110	3	A24	25
TPU 110-6	110	6	A25	30
TPU 110-10	110	10	A25	45
TPU 110-15	110	15	A25	80
TPU 110-20	110	20	A26	90
TPU 110-25	110	25	A26	125
TPU 110-30	110	30	B47	150
TPU 110-35	110	35	B47	220
TPU 110-40	110	40	B47	230
TPU 110-50	110	50	B47	250
TPU 110-60	110	60	B47	270
TPU 110-75	110	75	B47	290
TPU 110-100	110	100	B47	340

TPU 220-3	220	3	A21	20
TPU 220-6	220	6	A21	45
TPU 220-10	220	10	A21	90
TPU 220-15	220	15	A21	140
TPU 220-20	220	20	B36	215
TPU 220-25	220	25	B36	270
TPU 220-30	220	30	B47	300
TPU 220-35	220	35	B47	400
TPU 220-40	220	40	B47	450
TPU 220-50	220	50	B62	500
TPU 220-60	220	60	B62	520
TPU 220-75	220	75	B62	550
TPU 220-100	220	100	B62	625

Cabinet Dimension & Weight

TPU Three - Phase Battery Charger

Type	Nom. Volt. Vdc	Nom Cur. Adc	Cabinet	Wgt kg
TPU 300-24-25	24	25	B36	80
TPU 300-24-30	24	30	B36	100
TPU 300-24-35	24	35	B36	100
TPU 300-24-40	24	40	B36	120
TPU 300-24-50	24	50	B36	120
TPU 300-24-60	24	60	B47	120
TPU 300-24-75	24	75	B47	185
TPU 300-24-100	24	100	B47	190

TPU 300-30-25	30	25	B36	100
TPU 300-30-30	30	30	B36	120
TPU 300-30-35	30	35	B36	120
TPU 300-30-40	30	40	B47	140
TPU 300-30-50	30	50	B47	140
TPU 300-30-60	30	60	B47	140
TPU 300-30-75	30	75	B47	200
TPU 300-30-100	30	100	B47	220

TPU 300-48-25	48	25	B36	125
TPU 300-48-30	48	30	B36	130
TPU 300-48-35	48	35	B36	130
TPU 300-48-40	48	40	B47	150
TPU 300-48-50	48	50	B47	150
TPU 300-48-60	48	60	B47	150
TPU 300-48-75	48	75	B47	220
TPU 300-48-100	48	100	B47	245

Cabinet	H (mm)	W (mm)	D (mm)
A15	480	300	230
A16	550	400	320
A18	610	430	330
A19	650	400	320
A21	790	500	380
A22	900	610	370
A23	1100	700	470
A24	1500	670	470
A25	1700	800	620
A26	1800	900	670
B36	1230	670	490
B47	1630	670	490
B62	2028	840	800
B63	2028	940	800
B74	2260	800	800

Type	Nom. Volt. Vdc	Nom Cur. Adc	Cabinet	Wgt kg
TPU 300-110-25	110	25	B47	150
TPU 300-110-30	110	30	B47	170
TPU 300-110-35	110	35	B47	170
TPU 300-110-40	110	40	B47	205
TPU 300-110-50	110	50	B47	270
TPU 300-110-60	110	60	B47	325
TPU 300-110-75	110	75	B47	400
TPU 300-110-100	110	100	B47	425
TPU 300-110-110	110	110	B47	440
TPU 300-110-125	110	125	B47	455
TPU 300-110-150	110	150	B62	500
TPU 300-110-175	110	175	B62	520
TPU 300-110-200	110	200	B62	630
TPU 300-110-250	110	250	B62	720
TPU 300-110-300	110	300	B62	920
TPU 300-110-400	110	400	B62	1090
TPU 300-110-500	110	500	B62	1120
TPU 300-110-600	110	600	B62	1350
TPU 300-110-700	110	700	B62	1450
TPU 300-110-1000	110	1000	B62	1750

TPU 300-220-25	220	25	B47	190
TPU 300-220-30	220	30	B47	210
TPU 300-220-35	220	35	B47	210
TPU 300-220-40	220	40	B47	390
TPU 300-220-50	220	50	B47	390
TPU 300-220-60	220	60	B47	490
TPU 300-220-75	220	75	B47	490
TPU 300-220-100	220	100	B47	530
TPU 300-220-125	220	125	B62	570
TPU 300-220-150	220	150	B62	750
TPU 300-220-175	220	175	B62	810
TPU 300-220-200	220	200	B62	860
TPU 300-220-250	220	250	B62	1000
TPU 300-220-300	220	300	B62	1275
TPU 300-220-400	220	400	B62	1600
TPU 300-220-500	220	500	B62	1900
TPU 300-220-600	220	600	B63D	2200
TPU 300-220-700	220	700	B63D	2680
TPU 300-220-1000	220	1000	B63D	2780